

# Mathematics Chart

<b>LENGTH</b>	
<b>Metric</b>	<b>Customary</b>
1 kilometer = 1000 meters	1 mile = 1760 yards
1 meter = 100 centimeters	1 mile = 5280 feet
1 centimeter = 10 millimeters	1 yard = 3 feet
	1 foot = 12 inches
<b>CAPACITY AND VOLUME</b>	
<b>Metric</b>	<b>Customary</b>
1 liter = 1000 milliliters	1 gallon = 4 quarts
	1 gallon = 128 ounces
	1 quart = 2 pints
	1 pint = 2 cups
	1 cup = 8 ounces
<b>MASS AND WEIGHT</b>	
<b>Metric</b>	<b>Customary</b>
1 kilogram = 1000 grams	1 ton = 2000 pounds
1 gram = 1000 milligrams	1 pound = 16 ounces
<b>TIME</b>	
1 year = 365 days	
1 year = 12 months	
1 year = 52 weeks	
1 week = 7 days	
1 day = 24 hours	
1 hour = 60 minutes	
1 minute = 60 seconds	

Metric and customary rulers can be found on the separate Mathematics Chart.

Continued on the next page

**Mathematics Chart**

<b>Perimeter</b>	square	$P = 4s$
	rectangle	$P = 2l + 2w$ or $P = 2(l + w)$
<b>Area</b>	square	$A = s^2$
	rectangle	$A = lw$ or $A = bh$
	triangle	$A = \frac{1}{2}bh$ or $A = \frac{bh}{2}$

**DIRECTIONS**

Read each question. Then fill in the correct answer on your answer document.

**SAMPLE A**

Which digit is in the thousands place in the number 4,861,392?

- A**      6
- B**      4
- C**      1

**SAMPLE B**

Joey has 8 books. Bob has twice as many books as Joey has. How many books does Bob have?

- F**      2
- G**      16
- H**      20



1. Look at the figure below.

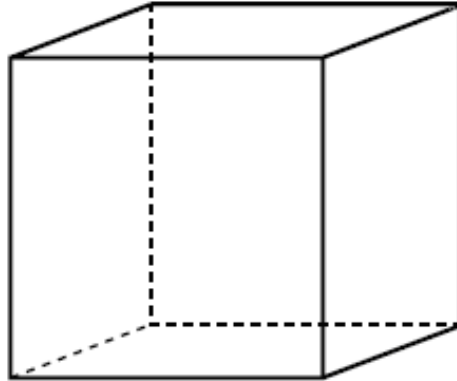

Which statement about this figure is true?

- A The figure has exactly 6 **faces**.
- B The figure has exactly 3 **edges**.
- C The figure has exactly 2 **vertices**.



2. A restaurant has 38 tables. Each table seats 4 people. If every table is full, how many people are seated in the restaurant at the same time?

- F** 49  
**G** 27  
**H** 152
- 

- 3.
- John is 8 years old.
  - Tim is 2 years older than Jon
  - Henry is twice as old as Tim.

Which number sentence could be used to find  $h$ , Henry's age?

- A**  $8 \times 2 = h$   
**B**  $(8 + 2) \times 2 = h$   
**C**  $8 \times 2 \div 2 = h$



4. Bert would like to decorate the store window with ribbon.

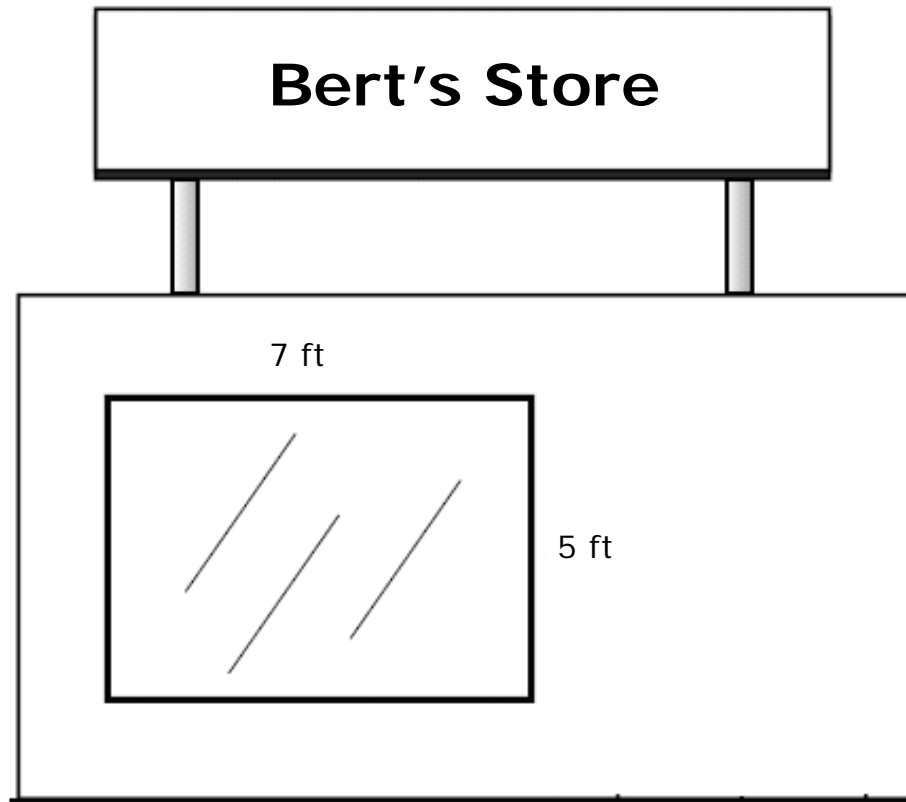

How many feet of ribbon will be needed to outline the 4 sides of the window?

- F** 8 ft
- G** 24 ft
- H** 95 ft



5. During a school project, students raised \$110.00 the first week and \$36.00 the second week. What should they do to see if they have met their goal of \$150.00?
- A Add \$110.00 and \$36.00 and compare the difference to \$150.00.
  - B Multiply \$110.00 by 2 and compare the product to \$150.00.
  - C Subtract \$36.00 from \$110.00 and compare the difference to \$150.00.



6. Which relationship between units of time is correct?

1 minute = 60 seconds 1 hour = 60 minutes 1 day = 24 hours 1 year = 365 days
---

- F** One day is  $\frac{1}{60}$  of one hour
- G** One second is  $\frac{1}{365}$  of one day
- H** One second is  $\frac{1}{60}$  of one minute



7. Each week Ann spends the same amount of money to buy her lunch at school. The table shows how much she spent over a number of weeks.

Number of Weeks	Total Amount Spent
6	\$60
7	\$70
8	\$80

Which is a way to find how much money Ann spends on lunches each week?

- A Subtract 8 from \$80
- B Add 7 and \$70
- C Divide \$60 by 6



8. If each number below is used only once, which group shows all the 3-digit numbers that can be made with these digits?

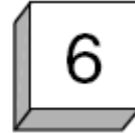
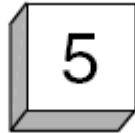

- F** 456, 565, 654
- G** 456, 465, 546, 564, 645, 654
- H** 456, 546



9. Carrie has 300 coins in her collection. She has 125 more coins than Michael. How many coins does Michael have?

**A** 175

**B** 425

**C** 200



10. A florist posted the sign below in his store window.

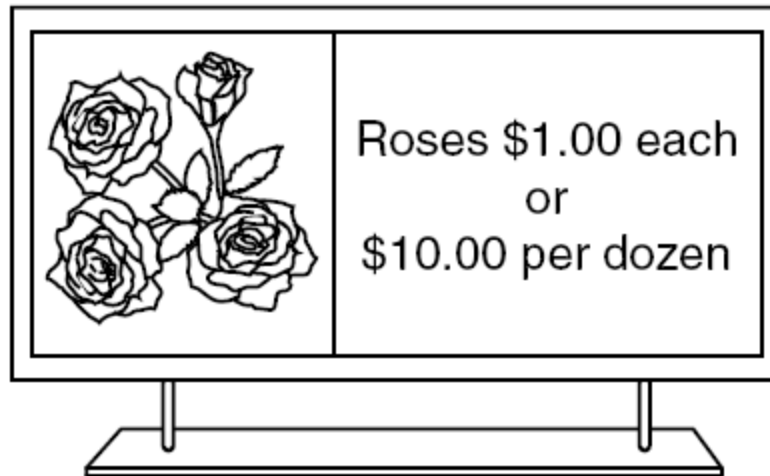

Carla needs to buy a dozen roses. Look at the sign. How much will she save by buying the roses by the dozen instead of buying 12 individually?

- F \$22.00
- G \$12.00
- H \$2.00



11. A **rectangular prism** made of 1-centimeter cubes is shown below.

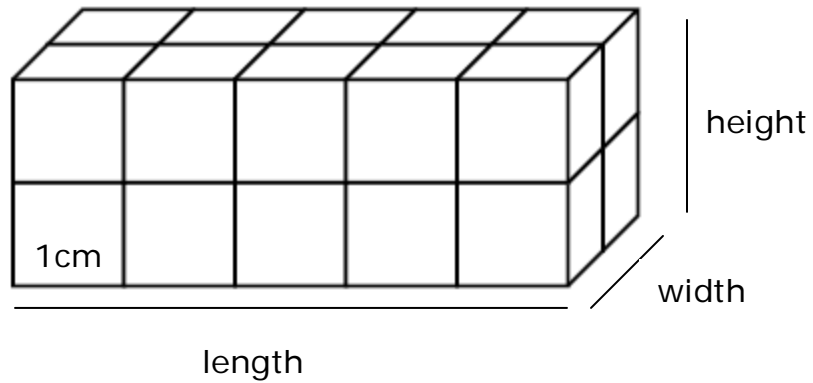

What is the **volume** of this rectangular prism?

- A 11  $\text{cm}^3$
- B 20  $\text{cm}^3$
- C 45  $\text{cm}^3$



**12.** How is the number 2,000,000,000 written in words?

- F** Two million
- G** Two thousand
- H** Two billion



13. The graph shows a figure with 4 points labeled.

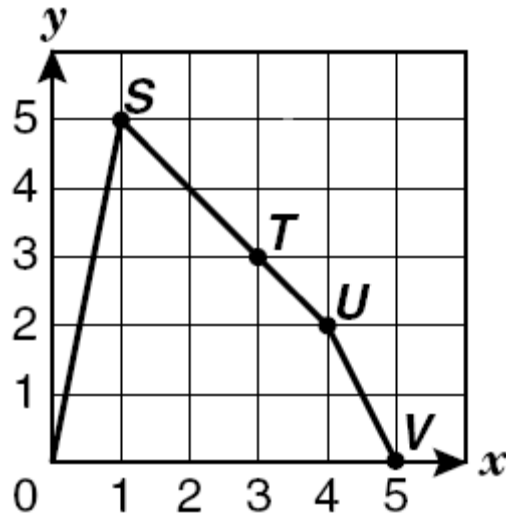

Which table shows the coordinates of these 4 points?

**A**

Point	S	T	U	V
x	1	3	4	5
y	5	3	2	0

**B**

Point	S	T	U	V
x	5	3	2	5
y	1	3	4	10

**C**

Point	S	T	U	V
x	5	3	4	0
y	1	3	2	5



**14.** Look for the pattern in sequences numbers below.

2, 4, 6, 8, 10

7, 14, 21, 28, 35

11, 22, 33, 44, 55

Each group of numbers is an example of which kind of numbers?

**F** Odd numbers

**G** Multiples

**H** Even numbers



15. Jim ran a race from 2:00 P.M. to 5:15 P.M., as shown on the clocks below.



Start

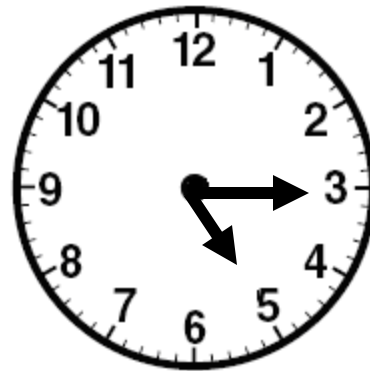

Finish

How many hours and minutes did Jim run?

- A 5 h 20 min
- B 1 h 5 min
- C 3 h 15 min



16. Which transformation is represented in the diagram?

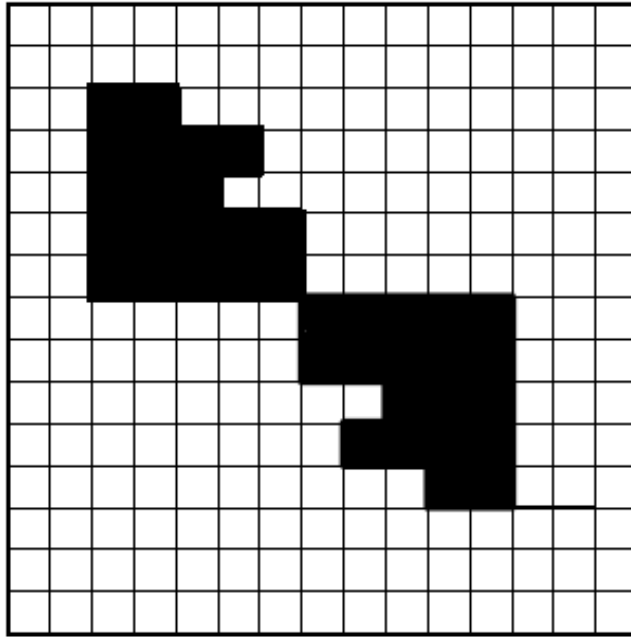

- F Translation
- G Reflection
- H Rotation



17. The table below shows the populations of 5 different cities.

### City Populations

City	Population
Riverside	32,701
Oceanside	45,006
Seaside	50,235
Mountainside	67,250
Lakeside	71,213

Which city in the table represents the median population?

- A Seaside
- B Lakeside
- C Riverside



- 18.** At a play, there were 843 people in the audience. The audience was seated in 3 sections. If each section had the same number of people in it, how many people were in each section?

**F** 2529

**G** 846

**H** 281

- 
- 19.** There are 10 ice cream bars in a box. How many boxes would you need to buy if you needed 100 ice cream bars?

**A** 2

**B** 10

**C** 50



20. How many ounces are in 6lbs?

1 pound = 16 ounces
---------------------

F 245 oz

G 8 oz

H 96 oz

---

21. There are 11 balls in a box.

- 4 are blue
- 1 is red
- 6 are yellow

If 1 ball is picked without looking, what is the probability that it will be blue?

A  $\frac{4}{7}$

B  $\frac{1}{4}$

C  $\frac{4}{11}$



**22.** The list below contains all the factors of which number?

1, 2, 3, 6, 9, 18, 27, 54

**F** 18

**G** 27

**H** 54



**23.**

Which decimal number represents the shaded part of this design?

- A** 0.5
- B** 0.2
- C** 0.003



**24.** Which shape could never have parallel sides?

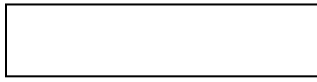

Rectangle

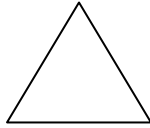

Triangle

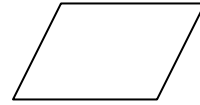

Rhombus

- F** Rhombus
- G** Triangle
- H** Rectangle



**25.** Look at the list of equivalent fractions.

$$\frac{1}{2}, \frac{2}{4}, \frac{3}{6}, \frac{4}{8}, \frac{5}{10}$$

What is the relationship between the numerator and denominator in each fraction?

- A** The numerator twice the denominator.
- B** The denominator is twice the numerator.
- C** The denominator is 7 more than the numerator.



26. Which of the following numbers is less than 6.021?

F 6.75

G 6.001

H 7.23

---

27. What fractional part of a liter is 250 milliliters?

1 liter = 1,000 milliliters

A  $\frac{1}{2}$

B  $\frac{1}{3}$

C  $\frac{1}{4}$



**28.** Which group shows all the numbers that are common factors of 36 and 48?

**F** 9, 12, 18

**G** 1, 2, 3, 4, 6, 12

**H** 3, 4, 6, 8



29. Pat gives his pet rabbit  $\frac{1}{3}$  cup of food in the morning and  $\frac{1}{3}$  cup of food in the afternoon, as shown in the measuring cups below.

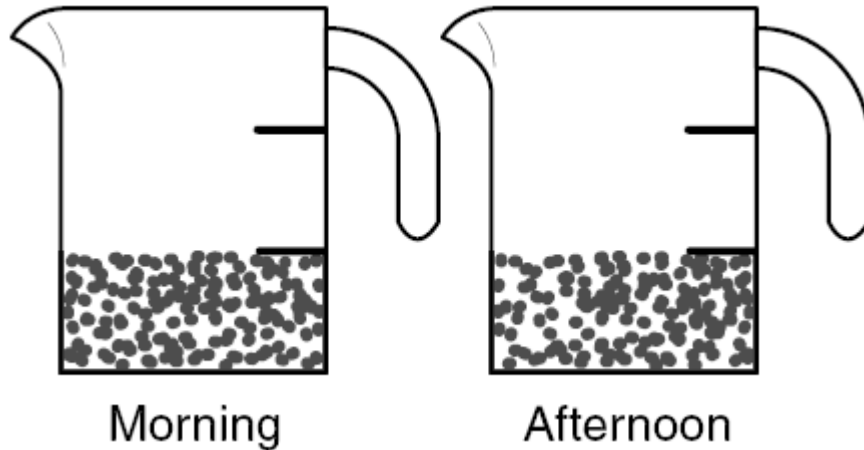

How much food does he give his rabbit each day?

- A  $\frac{1}{9}$
- B  $\frac{2}{3}$
- C  $\frac{2}{6}$

**GO ON** 

- 30.** A track team ran 4 miles in 36 minutes. Which number sentence shows how many minutes it took the team to run 1 mile?

**F**  $36 \div 4 = 9$

**G**  $36 + 4 = 40$

**H**  $36 - 4 = 32$

---

- 31.** A school basketball team won 10 of the 20 games it played. What fraction of its games did the team win?

**A**  $\frac{1}{20}$

**B**  $\frac{10}{30}$

**C**  $\frac{1}{2}$



32. Which figure below has 10 vertices?

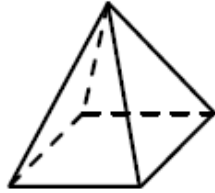

*U*

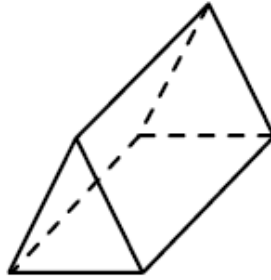

*V*

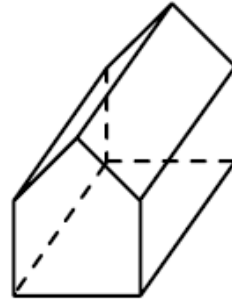

*X*

- F** *X*
- G** *U*
- H** *V*



33. Which pair of eagle pictures shows a translation?

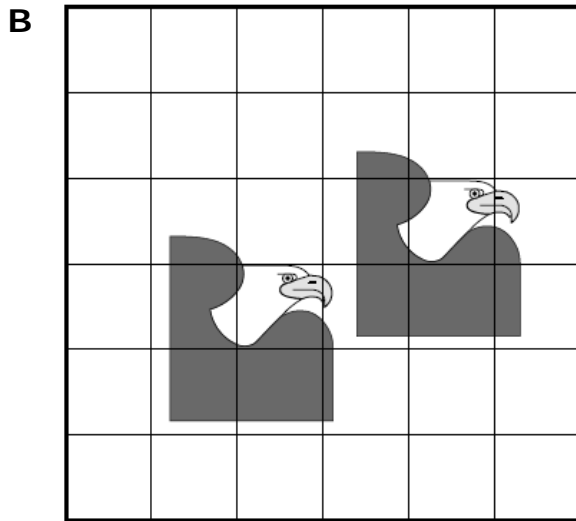
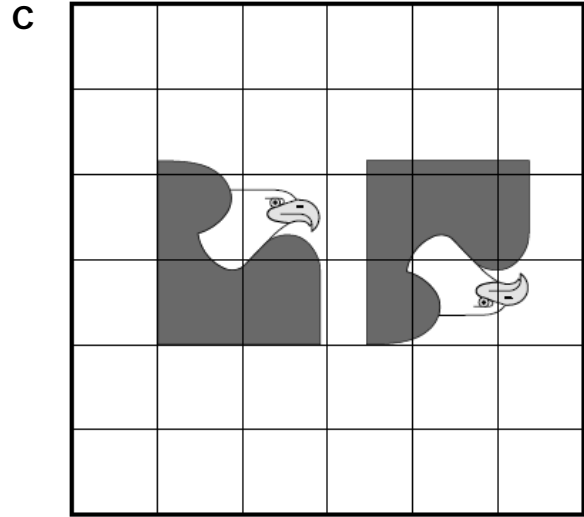
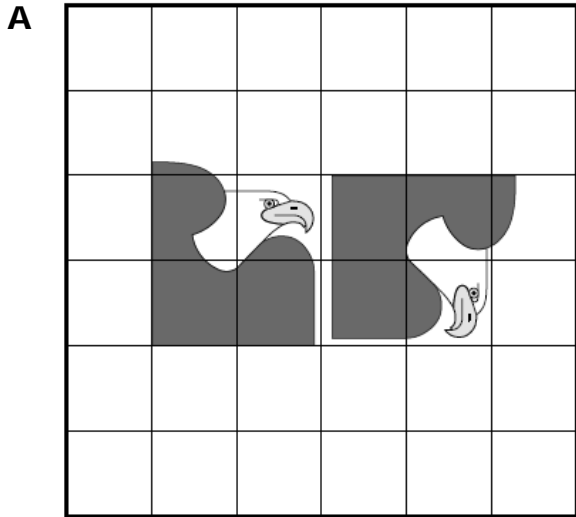

**GO ON** 

- 34.** A parking lot has 6 rows, with 24 spaces in each row. Which of the following shows a way to find the total number of spaces in the parking lot?

- F** Add 24 to 6
- G** Subtract 6 from 24
- H** Multiply 24 by 6



35. Joe made the grid below to show the location of some things in his yard.

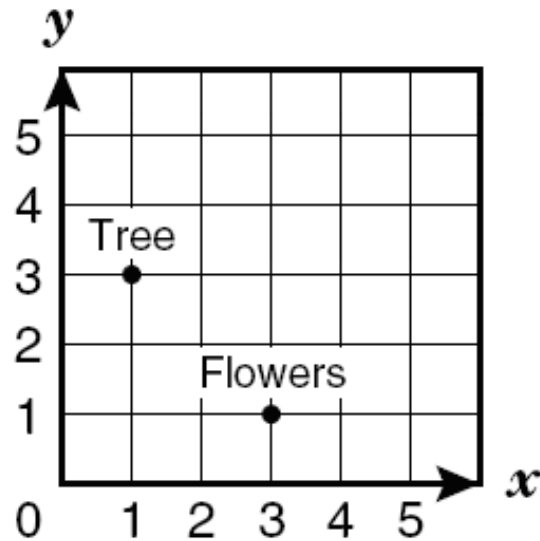

Which **ordered pair** best represents the point on the grid labeled "Tree"?

- A (3, 1)
- B (5, 2)
- C (1, 3)

