

# Mathematics Chart

## LENGTH

### Metric

1 kilometer = 1000 meters

1 meter = 100 centimeters

1 centimeter = 10 millimeters

### Customary

1 mile = 1760 yards

1 mile = 5280 feet

1 yard = 3 feet

1 foot = 12 inches

## CAPACITY AND VOLUME

### Metric

1 liter = 1000 milliliters

### Customary

1 gallon = 4 quarts

1 gallon = 128 ounces

1 quart = 2 pints

1 pint = 2 cups

1 cup = 8 ounces

## MASS AND WEIGHT

### Metric

1 kilogram = 1000 grams

1 gram = 1000 milligrams

### Customary

1 ton = 2000 pounds

1 pound = 16 ounces

## TIME

1 year = 365 days

1 year = 12 months

1 year = 52 weeks

1 week = 7 days

1 day = 24 hours

1 hour = 60 minutes

1 minute = 60 seconds

Metric and customary rulers can be found on the separate Mathematics Chart.

**Continued on the next page**

## Mathematics Chart

<b>Perimeter</b>	square	$P = 4s$
	rectangle	$P = 2l + 2w$ or $P = 2(l + w)$
<b>Circumference</b>	circle	$C = 2\pi r$ or $C = \pi d$
<b>Area</b>	square	$A = s^2$
	rectangle	$A = lw$ or $A = bh$
	triangle	$A = \frac{1}{2}bh$ or $A = \frac{bh}{2}$
	trapezoid	$A = \frac{1}{2}(b_1 + b_2)h$ or $A = \frac{(b_1 + b_2)h}{2}$
	circle	$A = \pi r^2$
<b>Surface Area</b>	cube	$S = 6s^2$
	cylinder (lateral)	$S = 2\pi rh$
	cylinder (total)	$S = 2\pi rh + 2\pi r^2$ or $S = 2\pi r(h + r)$
	cone (lateral)	$S = \pi rl$
	cone (total)	$S = \pi rl + \pi r^2$ or $S = \pi r(l + r)$
	sphere	$S = 4\pi r^2$
<b>Volume</b>	prism	$V = Bh^*$
	cylinder	$V = Bh^*$
	pyramid	$V = \frac{1}{3}Bh^*$
	cone	$V = \frac{1}{3}Bh^*$
	sphere	$V = \frac{4}{3}\pi r^3$
<i>*B represents the area of the Base of a solid figure.</i>		
<b>Pi</b>	$\pi$	$\pi \approx 3.14$ or $\pi \approx \frac{22}{7}$
<b>Pythagorean Theorem</b>		$a^2 + b^2 = c^2$
<b>Simple Interest Formula</b>		$I = prt$

**DIRECTIONS**

Read each question. Then fill in the correct answer on your answer document.

**SAMPLE A**

Find the greatest common factor of 12 and 18.

- A**      3
- B**      6
- C**      9

**SAMPLE B**

Find the perimeter of this square rug in meters.



3.2 m

- F**      12.8m
- G**      6.6m
- H**      5 m



1. The table below shows speed records for specific years.

**Land-Speed Records**

Driver	Year	Speed (mph)
Campbell	1935	301.13
Cobb	1947	394.20
Love	1965	600.60
Green	1997	763.04

Whose speed record was exactly 368.84 miles less per hour than Green's?

- A Campbell
- B Cobb
- C Love



2. A circle with a radius of 6 is shown below.

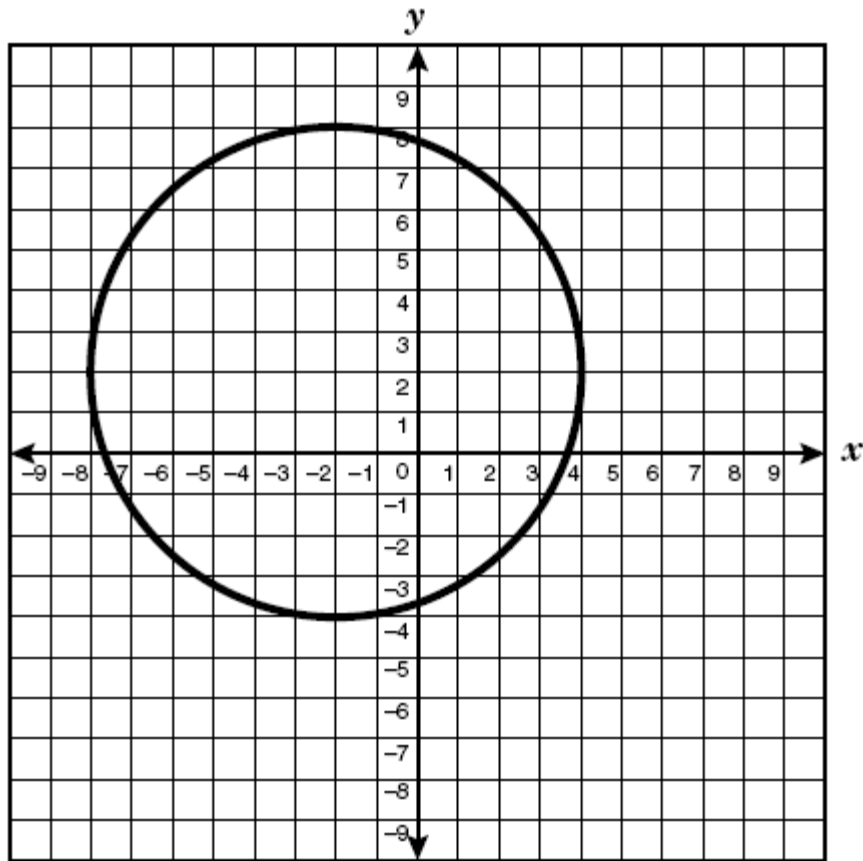

Which of the following are the coordinates of the center of the circle?

**F**  $(-6, -9)$

**G**  $(4, -5)$

**H**  $(-2, 2)$

**GO ON** 

3. Which expression below represents the number 0.000001 in scientific notation?

**A**  $1.0 \times 10^6$

**B**  $1.0 \times 10^{-7}$

**C**  $1.0 \times 10^{-6}$



4. The rectangular room below has an area of 875 square feet.

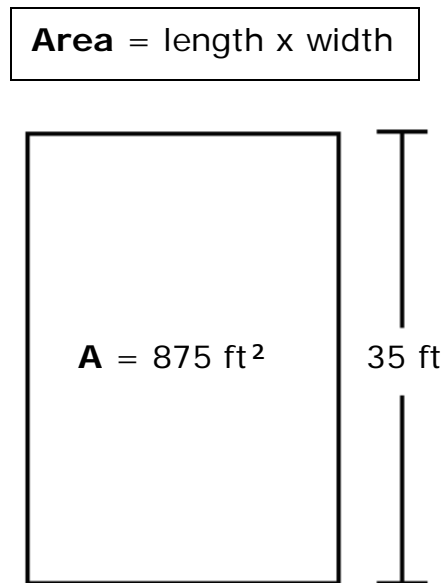

What is the width of the room if the length is 35 feet?

- F** 25 ft
- G** 20 ft
- H** 476 ft



5. Which line shown below represents the table of values for the ordered pairs  $(x, y)$ ?

$x$	$y$
-3	3.5
0	5
2	6
5	7.5

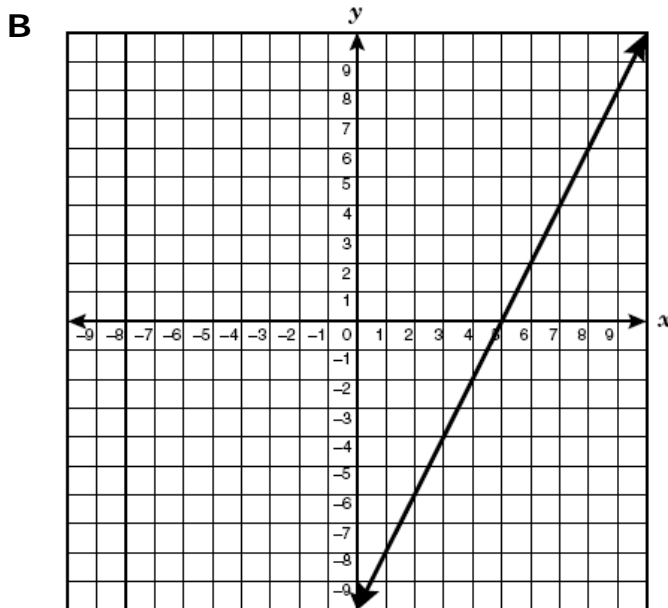
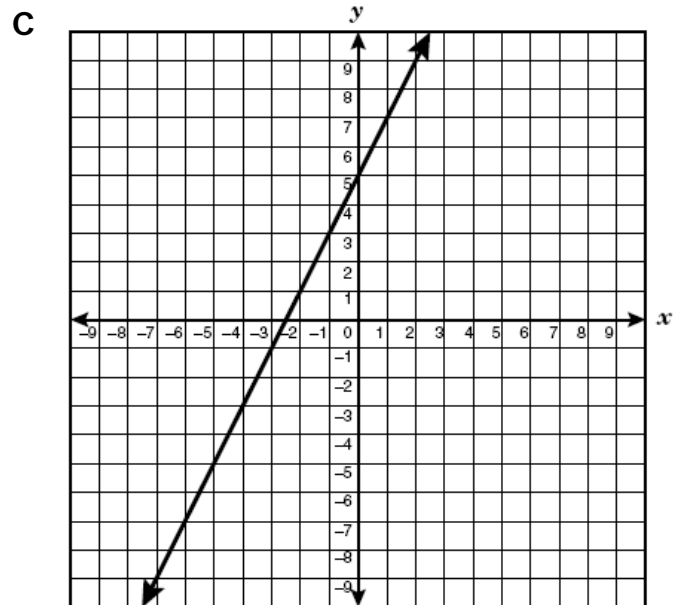
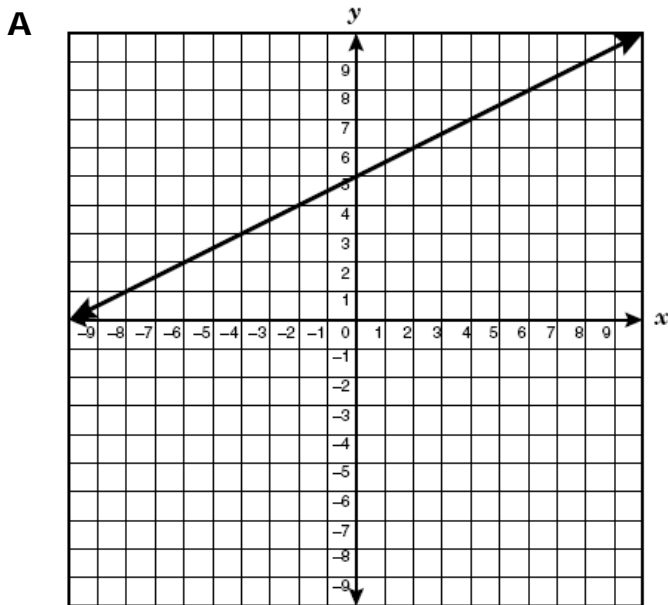

6. At Jones High School, 75% of the students wear boots to school at least two days a week.

If the school has 1,200 students, which statement below represents the school's data?

- F** 1,000 of the students never wear boots.
- G** During winter  $\frac{3}{4}$  of the students wear boots to school at least two days a week.
- H** 60% of the students are girls.



7. A pattern of equations is shown below.

$$1\% \text{ of } 800 = 8$$

$$2\% \text{ of } 400 = 8$$

$$4\% \text{ of } 200 = 8$$

$$8\% \text{ of } 100 = 8$$

$$16\% \text{ of } 50 = 8$$

Which statement describes this pattern of equations?

- A** When the percent is doubled and the number is halved, the answer is 8.
- B** When the percent is multiplied by 5 and the number is doubled, the answer is 8.
- C** When the percent is divided by 10 and the number is doubled, the answer is 8.



8. The scatterplot below shows the cost of phone calls Betsy made to her brother by the number of minutes for each phone call.

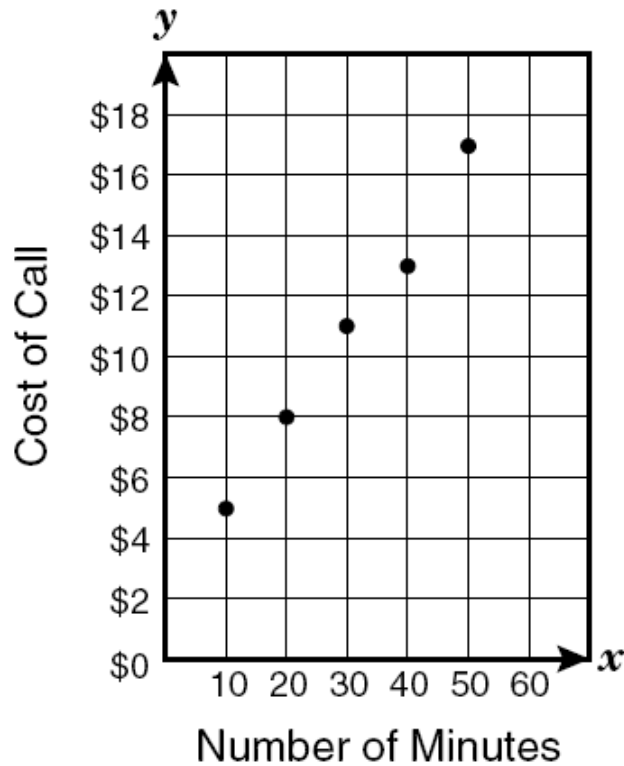

Based on the information in the scatterplot, which statement below is a correct statement?

- F The cost stayed at \$6 no matter how long Betsy stayed on the phone.
- G As Betsy increased the number of minutes on the phone, the cost of the phone calls decreased.
- H As Betsy increased the number of minutes on the phone, the cost of the phone calls increased.



9. After looking at the menu shown below, Mary bought Value Meal No. 2.

Menu		
<p><b>Value Meal #1</b> <b>\$4.29</b> Regular Burger, Medium Fries, Medium Drink</p>	<p><b>Sandwiches</b></p> <p>Regular Burger \$1.99 Bacon Burger \$2.39 Chicken Sandwich \$2.49 Fish Sandwich \$2.29</p>	<p><b>Sides</b></p> <p>Small Fries \$0.99 Medium Fries \$1.29 Large Fries \$1.69 Small Onion Rings \$1.19 Medium Onion Rings \$1.39 Large Onion Rings \$1.69</p>
<p><b>Value Meal #2</b> <b>\$4.69</b> Chicken Sandwich, Medium Fries, Medium Drink</p>	<p><b>Drinks</b></p> <p>Small Soft Drink \$0.99 Medium Soft Drink \$1.29 Large Soft Drink \$1.59 Shake or Malt \$1.89</p>	

Mary calculated her savings by finding the sum of \$2.49 plus 2 times \$1.29. What did Mary do next to calculate her savings?

- A Divide the sum by 2.
- B Subtract \$4.69 from the sum.
- C Subtract \$2.49 from the sum.



- 10.** Mr. Flores will run a 26.1-mile marathon. He would like to run the marathon in 4.5 hours. How many miles per hour should Mr. Flores run to complete the marathon in 4.5 hours?

**F** 5.8 mph

**G** 6.2 mph

**H** 5 mph



11. Regular pentagon MNPQR is similar to pentagon TUVWX.

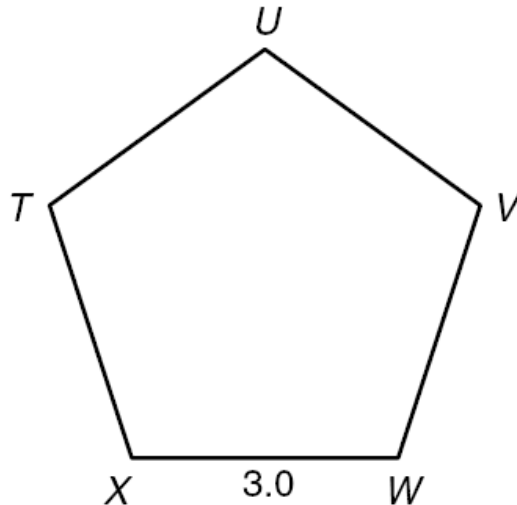
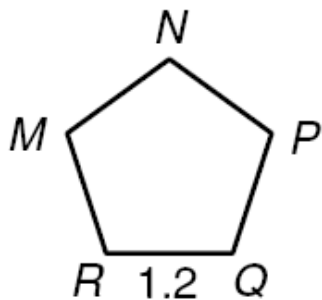

What scale factor was used to dilate regular pentagon MNPQR to pentagon TUVWX?

- A 1.8
- B 2.5
- C 4.2

**GO ON** 

- 12.** Cody's parents bought a big-screen television for \$1,099.99 and a DVD player for \$99.99. Cody's parents will pay the total amount in 18 equal monthly payments. What is a reasonable amount for each monthly payment?

**F** \$12.00

**G** \$67.00

**H** \$176.00



13. Mr. Elliott designed a flower garden in the shape of a square. He plans to build a sidewalk through the garden, as shown below.

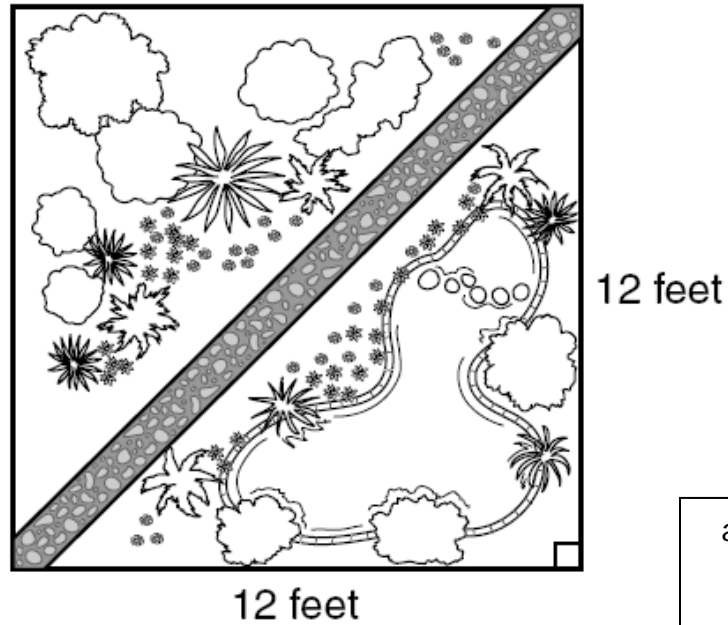

Which is closest to the length of the sidewalk?

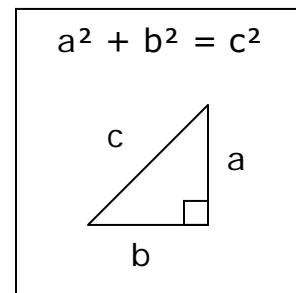

- A 8 ft
- B 45 ft
- C 17 ft



**14.** A store's sales for the week were:

\$436, \$650, \$530, \$500, \$650, \$489 \$423

Which measure of data would make the store's sales for the week appear the most profitable?

**F** Mode

**G** Range

**H** Median



- 15.** A company has 450 workers. It plans to increase the number of workers by 8 people per month until it has doubled in size. Which equation can be used to determine  $m$ , the number of months it will take for the company's number of workers to double in size?

**A**  $2(8m + 450) = 900$

**B**  $8m + 450 = 900$

**C**  $2m + 450 = 900$



- 16.** Rob is building a model of an actual airplane, which is 20 feet long.

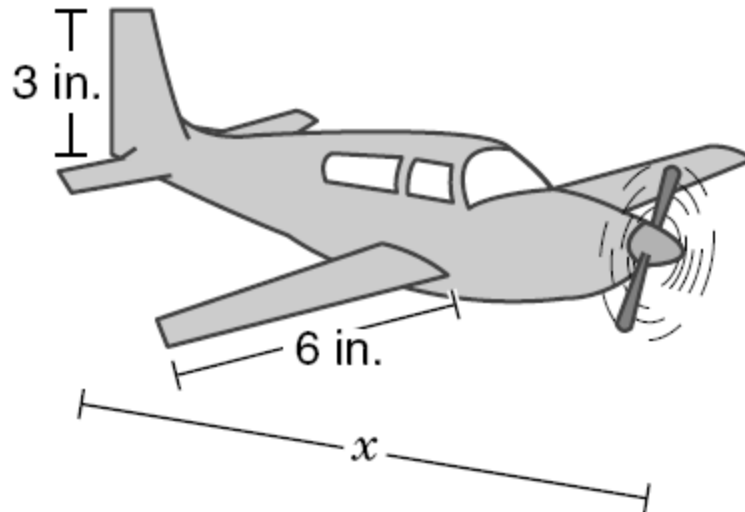

What other information is necessary in order to find  $x$ , the length of the model airplane?

- F** How fast the actual airplane could fly
- G** The speed of the model airplane
- H** The scale factor used



- 17.** Sheila made a scale drawing of a room. The actual room has a width of 16 feet and a length of 24 feet. Her drawing has a length of 3 inches. What is the width, in inches, of the scale drawing of the room?

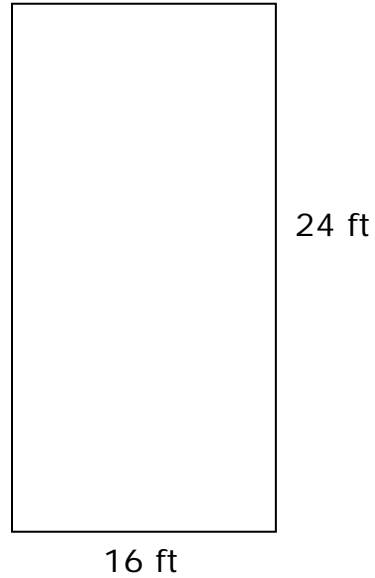
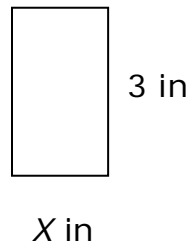

- A** 2 in  
**C** 8 in  
**H** 14 in



- 18.** To make a certain shade of orange paint, Calvin must add 20 ounces of yellow paint to every 50 ounces of red paint.

If he uses 200 ounces of red paint, which answer below best represents how he can find the number of ounces of yellow paint he will need to add to make the orange paint?

**F**  $\frac{20}{50} = \frac{x}{200}$

**G**  $\frac{20}{30} = \frac{x}{200}$

**H**  $\frac{20}{200} = \frac{x}{50}$



- 19.** Mr. Johnson wants to rent an office.

It has 325 square feet of space, and the rent is \$1,300 per month.

A larger office in the same building is available for \$2,100 per month at the same rate per square foot as the smaller office.

What is the area of the larger office?

- A** 525 ft<sup>2</sup>
- B** 1,625 ft<sup>2</sup>
- C** 840 ft<sup>2</sup>

- 
- 20.** Which fraction is between  $\frac{2}{3}$  and  $\frac{3}{4}$ ?

- F**  $\frac{7}{8}$
- G**  $\frac{3}{5}$
- H**  $\frac{5}{7}$



- 21.** Mr. Thomas is building a 28 x 40 foot concrete patio. The concrete company charges \$120.00 per cubic yard of concrete. What other information is needed to find, the cost of the concrete patio?

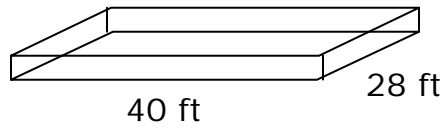

- A** The area of the patio
- B** The thickness of the patio
- C** The perimeter of the patio



22. If  $\triangle XYZ$  is translated 8 units to the left and 3 units down, what are the new Y coordinates, point  $Y'$ ?

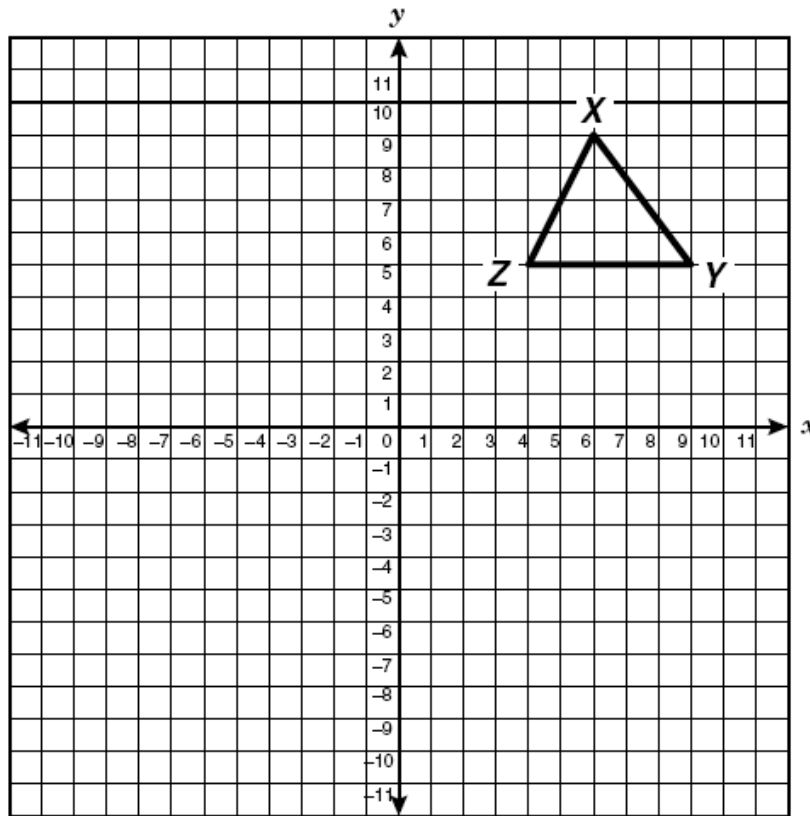

- F** (1, 5)  
**G** (-2, 6)  
**H** (1, 2)



23. Rectangle STUV is similar to rectangle LMNO.

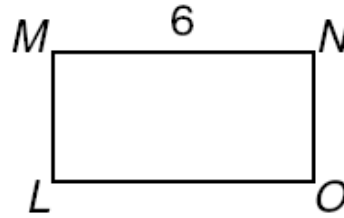
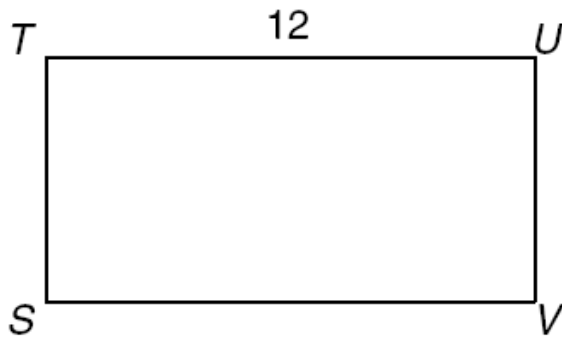

If the area of rectangle STUV is 72 square units, what is the area of rectangle LMNO?

- A 30 units<sup>2</sup>
- B 24 units<sup>2</sup>
- C 18 units<sup>2</sup>



- 24.** A 5-pound bag of white potatoes costs \$4.25. If red potatoes cost \$0.89 per pound, why would the white potatoes be the better buy?
- F** The red potatoes were bigger.
- G** The number of white potatoes in a 5-pound bag is greater than the number of red potatoes in a 5-pound bag.
- H** The cost per pound of white potatoes is \$0.04 less than the cost per pound of red potatoes.



25. The figure below shows three shaded equilateral triangles inside a rectangle.

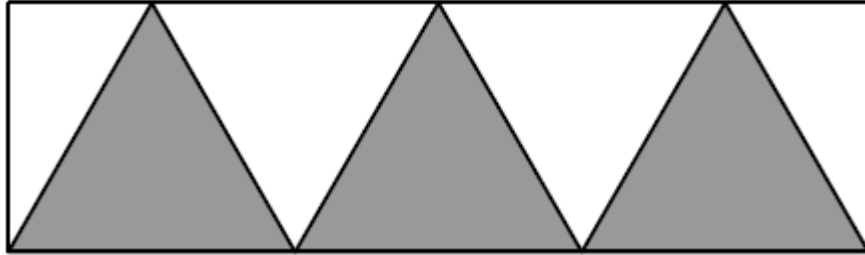

Which statement about this figure is true?

- A** The shaded area is equal to the unshaded area of the rectangle.
- B** The unshaded area is  $\frac{2}{3}$  of the shaded area of the rectangle.
- C** The shaded area is more than  $\frac{1}{2}$  the area of the rectangle.



26. In the sequence below, which expression can be used to find the value of the  $n^{\text{th}}$  term?

Position	Value of Term
1	0.25
2	0.5
3	0.75
4	1.0
5	1.25
$n$	

F  $n - 0.75$

G  $\frac{n}{4}$

H  $4n - 3$



27. Jonathan wrapped a birthday gift in a cubical box.

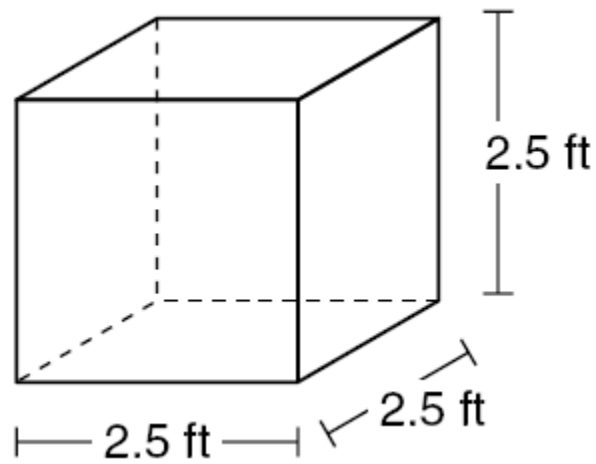

Which is closest to the surface area of the box?

- A 16 sq. ft.
- B 38 sq. ft.
- C 134 sq. ft.



**28.** On Monday Chris's mother gave him money for school.

- He spent \$2.80 for lunch every day for 5 days.
- He spent \$0.75 books.
- He spent \$3.50 for school supplies.

If Chris had \$1.75 left at the end of the week, which expression can he use to find the amount of money his mom gave him on Monday?

**F**  $1.75 + 5(2.80) + 3.50 + 0.75$

**G**  $5(2.80) + 0.75 + 3.50 - 1.75$

**H**  $10.00 + 0.75 + 3.50 + 0.75$

---

**29.** On Friday, the low temperature in Alaska was  $-12^{\circ}\text{F}$ , and the high temperature was  $23^{\circ}\text{F}$ . How much warmer was the high temperature than the low temperature?

**A**  $-110^{\circ}\text{F}$

**B**  $11^{\circ}\text{F}$

**C**  $35^{\circ}\text{F}$



30. Trapezoid STUV is similar to trapezoid NOPQ.

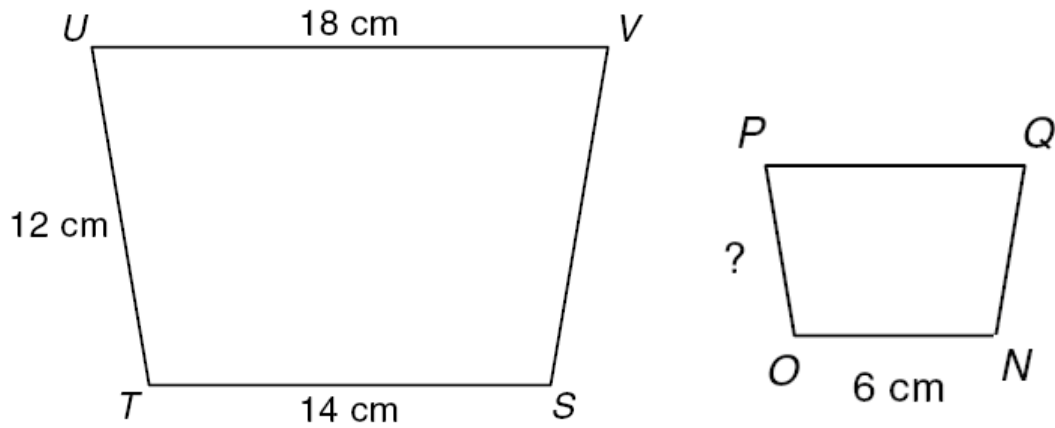

What is the length of  $\overline{OP}$ ?

- F 7 centimeters
- G  $5\frac{1}{7}$  centimeters
- H  $4\frac{2}{3}$  centimeters

GO ON 

- 31.** A family went on a camping trip. They paid \$28.00 for a 2-night stay at a campground with a maximum stay of 30 nights. Which equation can be used to find  $c$ , the cost of camping at this campground for the maximum number of nights?

**A**  $c = 30 \cdot 14$

**B**  $c = 30 \cdot 28$

**C**  $c = 15 \cdot 28$



32. A toy truck wheel is shown below.

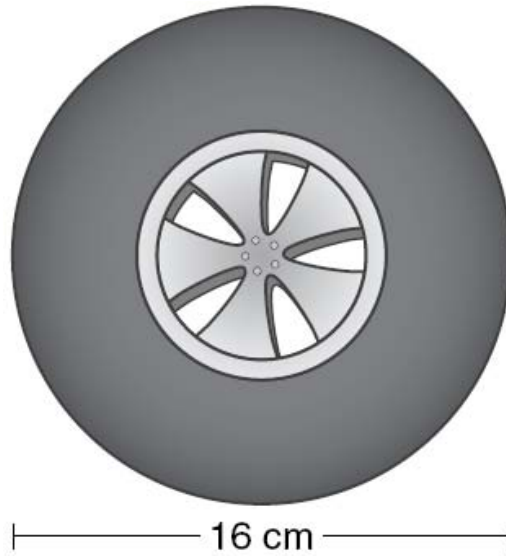

**Circumference:**  $C = \pi \cdot \text{diameter}$

Which number is closest to the distance traveled by the truck during 2 full rotations of the wheel?

- F 23 centimeters
- G 100.5 centimeters
- H 4,238 centimeters



**33.** Vince has a spinner like the one shown below.

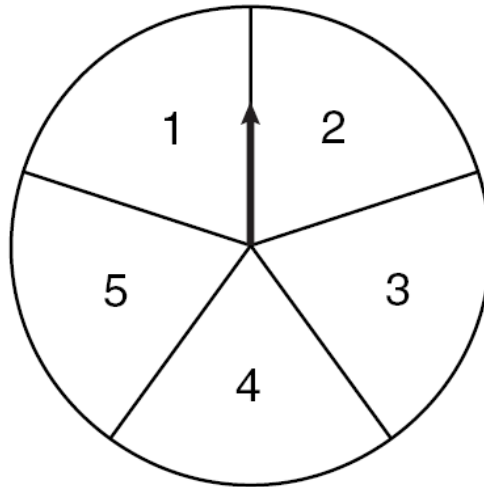

Vince wants to increase the chances of the following events:

- Spinning an even number
- Spinning a number less than 4
- Spinning the square root of 9

Vince decides to remove the 5 from the spinner. Which statement best supports his decision?

- A** Spinning the number 5 has the greatest probability.
- B** Spinning the number 5 is not a desired event.
- C** 5 is a prime number.



**34.** Which irrational number is closest to 3?

**F**  $\sqrt{81}$

**G**  $\sqrt{10}$

**H**  $\sqrt{25}$

---

**35.** Which number represents  $2.7 \times 10^7$  in standard notation?

**A** 2,700,000

**B** 2,700

**C** 27,000,000



36. The picture below shows a toolbox with a black handle.

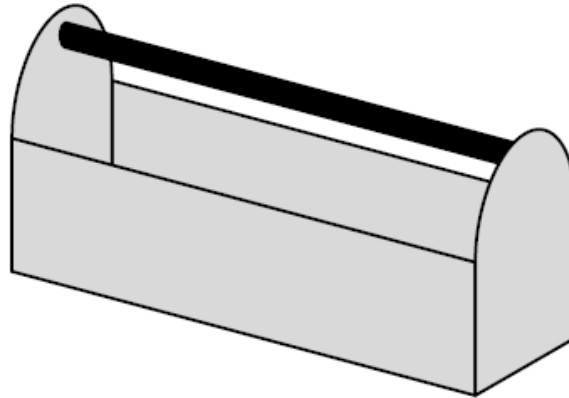

Which drawing best represents a top view of the toolbox?

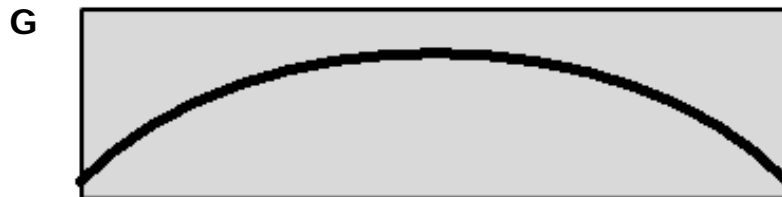

- 37.** Kevin's grades for English during a six-week period of time were 88, 75, 92, 73, 74, and 86. Which of the following is the mean of Kevin's grades?

- A** 78.7  
**B** 81.3  
**C** 80.1
- 

- 38.** A gift basket contains

- $6\frac{2}{3}$  ounces of chocolate candy
- $4\frac{1}{2}$  ounces of hard candy
- 4 ounces of nuts

What is the total weight of the candy and nuts in the basket?

- F** 15 ounces  
**G** 24 ounces  
**H** 10 ounces



- 39.** The probability of a basketball being defective is  $\frac{1}{10}$ .  
Approximately how many balls would be defective in a case of 725 basketballs?

**A** 367

**B** 80

**C** 73



40. The scatterplot below shows the number of households with cable television.

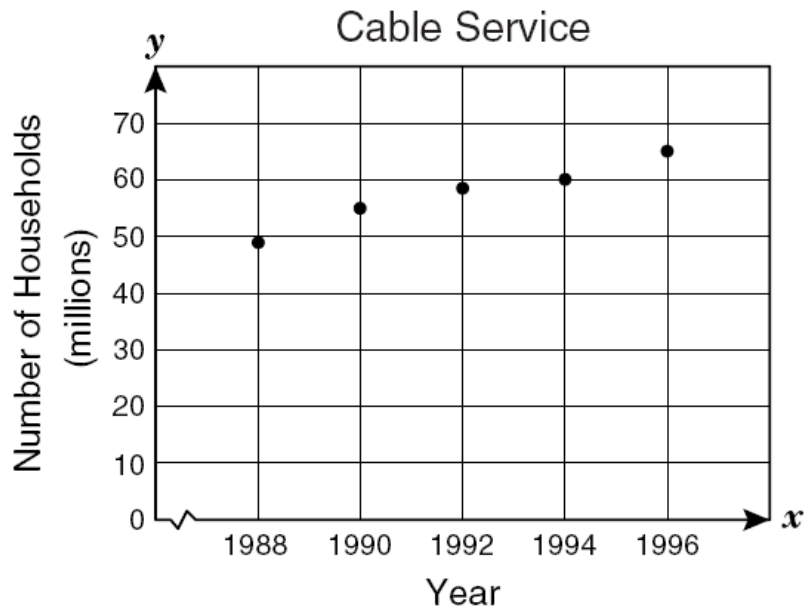

Which statement best describes the relationship on the scatterplot?

- F** The number of households with cable service increased over time.
- G** The number of households with cable service decreased over time.
- H** The lowest number of households with cable was recorded in 1994.

